



Series GEFH1/2



SET ~ 2

रोल नं.
Roll No.



प्रश्न-पत्र कोड
Q.P. Code 55/2/2

परीक्षार्थी प्रश्न-पत्र कोड को उत्तर-पुस्तिका के मुख-पृष्ठ पर अवश्य लिखें।

Candidates must write the Q.P. Code on the title page of the answer-book. ^

भौतिक विज्ञान (सैद्धान्तिक) PHYSICS (Theory)

निर्धारित समय : 3 घण्टे

अधिकतम अंक : 70

Time allowed : 3 hours

Maximum Marks : 70

नोट / NOTE :

- | | |
|-------|---|
| (i) | कृपया जाँच कर लें कि इस प्रश्न-पत्र में मुद्रित पृष्ठ 23 हैं।
Please check that this question paper contains 23 printed pages. |
| (ii) | प्रश्न-पत्र में दाहिने हाथ की ओर दिए गए प्रश्न-पत्र कोड को परीक्षार्थी उत्तर-पुस्तिका के मुख-पृष्ठ पर लिखें।
Q.P. Code given on the right hand side of the question paper should be written on the title page of the answer-book by the candidate. |
| (iii) | कृपया जाँच कर लें कि इस प्रश्न-पत्र में 35 प्रश्न हैं।
Please check that this question paper contains 35 questions. |
| (iv) | कृपया प्रश्न का उत्तर लिखना शुरू करने से पहले, उत्तर-पुस्तिका में प्रश्न का क्रमांक अवश्य लिखें।
Please write down the serial number of the question in the answer-book before attempting it. |
| (v) | इस प्रश्न-पत्र को पढ़ने के लिए 15 मिनट का समय दिया गया है। प्रश्न-पत्र का वितरण पूर्वाह्न में 10.15 बजे किया जाएगा। 10.15 बजे से 10.30 बजे तक परीक्षार्थी केवल प्रश्न-पत्र को पढ़ेंगे और इस अवधि के दौरान वे उत्तर-पुस्तिका पर कोई उत्तर नहीं लिखेंगे।
15 minute time has been allotted to read this question paper. The question paper will be distributed at 10.15 a.m. From 10.15 a.m. to 10.30 a.m., the candidates will read the question paper only and will not write any answer on the answer-book during this period. |



55/2/2

244 B

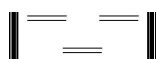

Page 1 of 24

P.T.O.





सामान्य निर्देश :

निम्नलिखित निर्देशों को बहुत सावधानी से पढ़िए और उनका पालन कीजिए :

- (i) इस प्रश्न पत्र में 35 प्रश्न हैं। सभी प्रश्न अनिवार्य हैं।
- (ii) प्रश्न पत्र पाँच खण्डों में विभाजित है – खण्ड-क, ख, ग, घ तथा ङ।
- (iii) खण्ड – क में प्रश्न संख्या 1 से 18 तक बहुविकल्पीय प्रकार के एक-एक अंक के प्रश्न हैं।
- (iv) खण्ड – ख में प्रश्न संख्या 19 से 25 तक लघु उत्तरीय प्रकार-1 के दो-दो अंकों के प्रश्न हैं।
- (v) खण्ड – ग में प्रश्न संख्या 26 से 30 तक लघु उत्तरीय प्रकार-2 के तीन-तीन अंकों के प्रश्न हैं।
- (vi) खण्ड – घ में प्रश्न संख्या 31 से 33 तक दीर्घ उत्तरीय प्रकार के पाँच-पाँच अंकों के प्रश्न हैं।
- (vii) खण्ड – ङ में प्रश्न संख्या 34 तथा 35 केस आधारित चार-चार अंकों के प्रश्न हैं।
- (viii) प्रश्न-पत्र में समग्र विकल्प नहीं दिया गया है। यद्यपि, खण्ड-ख के 2 प्रश्नों में, खण्ड-ग के 2 प्रश्नों में, खण्ड-घ के 3 प्रश्नों में तथा खण्ड-ङ के 2 प्रश्नों में आंतरिक विकल्प का प्रावधान दिया गया है।
- (ix) कैल्कुलेटर का उपयोग वर्जित है।

$$c = 3 \times 10^8 \text{ m/s}$$

$$h = 6.63 \times 10^{-34} \text{ Js}$$

$$e = 1.6 \times 10^{-19} \text{ C}$$

$$\mu_0 = 4\pi \times 10^{-7} \text{ T m A}^{-1}$$

$$\epsilon_0 = 8.854 \times 10^{-12} \text{ C}^2 \text{ N}^{-1} \text{ m}^{-2}$$

$$\frac{1}{4\pi\epsilon_0} = 9 \times 10^9 \text{ N m}^2 \text{ C}^{-2}$$

$$\text{इलेक्ट्रॉन का द्रव्यमान (m}_e\text{)} = 9.1 \times 10^{-31} \text{ kg}$$

$$\text{न्यूट्रॉन का द्रव्यमान} = 1.675 \times 10^{-27} \text{ kg}$$

$$\text{प्रोटॉन का द्रव्यमान} = 1.673 \times 10^{-27} \text{ kg}$$

$$\text{आवोगाद्रो संख्या} = 6.023 \times 10^{23} \text{ प्रति ग्राम मोल}$$

$$\text{बोल्ट्जमान नियतांक} = 1.38 \times 10^{-23} \text{ JK}^{-1}$$

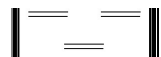



General Instructions :

Read the following instructions very carefully and follow them :

- (i) This question paper contains **35** questions. **All** questions are compulsory.
- (ii) Question paper is divided into **FIVE** sections – Section **A, B, C, D** and **E**.
- (iii) In **Section A** : Question number **1 to 18** are Multiple Choice (MCQ) type questions carrying **1** mark each.
- (iv) In **Section B** : Question number **19 to 25** are Short Answer-1 (SA-1) type questions carrying **2** marks each.
- (v) In **Section C** : Question number **26 to 30** are Short Answer-2 (SA-2) type questions carrying **3** marks each.
- (vi) In **Section D** : Question number **31 to 33** are Long Answer (LA) type questions carrying **5** marks each.
- (vii) In **Section E** : Question number **34 and 35** are Case-Based questions carrying **4** marks each.
- (viii) There is no overall choice. However, an internal choice has been provided in **2** questions in Section–**B**, **2** questions in Section–**C**, **3** questions in Section–**D** and **2** questions in Section–**E**.
- (ix) Use of calculators is **NOT** allowed.

$$c = 3 \times 10^8 \text{ m/s}$$

$$h = 6.63 \times 10^{-34} \text{ Js}$$

$$e = 1.6 \times 10^{-19} \text{ C}$$

$$\mu_0 = 4\pi \times 10^{-7} \text{ T m A}^{-1}$$

$$\epsilon_0 = 8.854 \times 10^{-12} \text{ C}^2 \text{ N}^{-1} \text{ m}^{-2}$$

$$\frac{1}{4\pi\epsilon_0} = 9 \times 10^9 \text{ N m}^2 \text{ C}^{-2}$$

$$\text{Mass of electron (} m_e \text{)} = 9.1 \times 10^{-31} \text{ kg}$$

$$\text{Mass of neutron} = 1.675 \times 10^{-27} \text{ kg}$$

$$\text{Mass of proton} = 1.673 \times 10^{-27} \text{ kg}$$

$$\text{Avogadro's number} = 6.023 \times 10^{23} \text{ per gram mole}$$

$$\text{Boltzmann constant} = 1.38 \times 10^{-23} \text{ JK}^{-1}$$

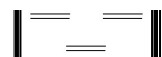



खण्ड - क

1. किसी समतल विद्युतचुम्बकीय तरंग के विद्युत क्षेत्र और चुम्बकीय क्षेत्र के परिमाणों का अनुपात होता है – 1
- (a) 1 (b) $\frac{1}{c}$
(c) c (d) $\frac{1}{c^2}$
2. हाइड्रोजन परमाणु के बोर मॉडल में इलेक्ट्रॉन का वह संक्रमण जिसमें उच्चतम तरंगदैर्घ्य की स्पेक्ट्रमी रेखा प्राप्त होती है, कौन सा है ? 1
- (a) $n = 3$ से $n = 1$ (b) $n = 3$ से $n = 2$
(c) $n = 4$ से $n = 1$ (d) $n = 4$ से $n = 2$
3. वायु में संचरण करती एकवर्णी प्रकाश की कोई किरण जल के पृष्ठ पर आपतन कर रही है। निम्नलिखित में से कौन परावर्तित और अपवर्तित किरणों के लिए समान होगा ? 1
- (a) वहन की गयी ऊर्जा (b) चाल
(c) आवृत्ति (d) तरंगदैर्घ्य
4. किसी p-n संधि डायोड में हासी क्षेत्र निर्मित होने का कारण है 1
- (a) मादक परमाणुओं की गति (b) इलेक्ट्रॉनों और विवरों दोनों का विसरण
(c) केवल इलेक्ट्रॉनों का अपवाह (d) केवल विवरों का अपवाह
5. कोई विलगित बिन्दु आवेश अपने से 3 m दूरी के किसी बिन्दु पर कोई विद्युत क्षेत्र \vec{E} उत्पन्न करता है। उस बिन्दु की इसी आवेश से दूरी क्या होगी जिस पर विद्युत क्षेत्र $\frac{\vec{E}}{4}$ है ? 1
- (a) 2 m (b) 3 m
(c) 4 m (d) 6 m
6. बंधन ऊर्जा प्रति न्यूक्लियॉन को द्रव्यमान संख्या का फलन मानकर खींचे गए वक्र पर हीलियम नाभिक के लिए तीक्ष्ण शिखर है। इससे यह ध्वनित होता है कि हीलियम नाभिक 1
- (a) रेडियोएक्टिव है।
(b) अस्थायी है।
(c) सरलता से विखण्डनीय है।
(d) अपने निकट के नाभिक से अधिक स्थायी है।





SECTION – A

1. The ratio of the magnitudes of the electric field and magnetic field of a plane electromagnetic wave is 1
- (a) 1 (b) $\frac{1}{c}$
(c) c (d) $\frac{1}{c^2}$
2. Specify the transition of electron in the wavelength of the line in the Bohr model of hydrogen atom which gives rise to the spectral line of highest wavelength. 1
- (a) $n = 3$ to $n = 1$ (b) $n = 3$ to $n = 2$
(c) $n = 4$ to $n = 1$ (d) $n = 4$ to $n = 2$
3. A ray of monochromatic light propagating in air, is incident on the surface of water. Which of the following will be the same for the reflected and refracted rays ? 1
- (a) Energy carried (b) Speed
(c) Frequency (d) Wavelength
4. The formation of depletion region in a p-n junction diode is due to 1
- (a) movement of dopant atoms (b) diffusion of both electrons and holes
(c) drift of electrons only (d) drift of holes only
5. An isolated point charge particle produces an electric field \vec{E} at a point 3 m away from it. The distance of the point at which the field is $\frac{\vec{E}}{4}$ will be 1
- (a) 2 m (b) 3 m
(c) 4 m (d) 6 m
6. The curve of binding energy per nucleon as a function of atomic mass number has a sharp peak for helium nucleus. This implies that helium nucleus is 1
- (a) radioactive
(b) unstable
(c) easily fissionable
(d) more stable nucleus than its neighbours





7. किसी तार से 8 mA की स्थायी धारा प्रवाहित हो रही है। 10 s में इस तार की किसी अनुप्रस्थ-काट से प्रवाहित होने वाले इलेक्ट्रॉनों की संख्या है – 1
- (a) 4.0×10^{16} (b) 5.0×10^{17}
(c) 1.6×10^{16} (d) 1.0×10^{17}
8. नीचे दिए गए तत्वों में से किससे एक इलेक्ट्रॉन को बाहर निकालने के लिए सबसे अधिक ऊर्जा की आवश्यकता होगी ? 1
- Pb, Ge, C और Si
- (a) Ge (b) C
(c) Si (d) Pb
9. 10Ω का एक चालक 6 V के आदर्श स्रोत से संयोजित है। स्रोत से चालक को आपूर्तित शक्ति है – 1
- (a) 1.8 W (b) 2.4 W
(c) 3.6 W (d) 7.2 W
10. किसी अपद्रव्यी अर्धचालक में विवरों का संख्या घनत्व $4 \times 10^{20} \text{ m}^{-3}$ है। यदि नैज वाहकों का संख्या घनत्व $1.2 \times 10^{15} \text{ m}^{-3}$ है, तो इसमें इलेक्ट्रॉनों का संख्या घनत्व है 1
- (a) $1.8 \times 10^9 \text{ m}^{-3}$ (b) $2.4 \times 10^{10} \text{ m}^{-3}$
(c) $3.6 \times 10^9 \text{ m}^{-3}$ (d) $3.2 \times 10^{10} \text{ m}^{-3}$
11. किसी बाह्य प्रतिरोध R के सिरों से emf E का कोई सेल संयोजित है। जब सेल से धारा I ली जाती है तो सेल के इलेक्ट्रोडों के बीच विभवान्तर घटकर V हो जाता है। सेल का आन्तरिक प्रतिरोध 'r' है 1
- (a) $\left(\frac{E - V}{E}\right) R$ (b) $\left(\frac{E - V}{R}\right)$
(c) $\frac{(E - V) R}{I}$ (d) $\left(\frac{E - V}{V}\right) R$
12. किसी धातु के पृष्ठ पर 663 nm तरंगदैर्घ्य का कोई फोटॉन आपतन कर रहा है। इस धातु का कार्यफलन 1.50 eV है। उत्सर्जित फोटो इलेक्ट्रॉनों की अधिकतम गतिज ऊर्जा है 1
- (a) $3.0 \times 10^{-20} \text{ J}$
(b) $6.0 \times 10^{-20} \text{ J}$
(c) $4.5 \times 10^{-20} \text{ J}$
(d) $9.0 \times 10^{-20} \text{ J}$





7. A steady current of 8 mA flows through a wire. The number of electrons passing through a cross-section of the wire in 10 s is 1
- (a) 4.0×10^{16} (b) 5.0×10^{17}
(c) 1.6×10^{16} (d) 1.0×10^{17}
8. Which one of the following elements will require the highest energy to take out an electron from them ? 1
Pb, Ge, C and Si
- (a) Ge (b) C
(c) Si (d) Pb
9. A conductor of 10Ω is connected across a 6 V ideal source. The power supplied by the source to the conductor is 1
- (a) 1.8 W (b) 2.4 W
(c) 3.6 W (d) 7.2 W
10. In an extrinsic semiconductor, the number density of holes is $4 \times 10^{20} \text{ m}^{-3}$. If the number density of intrinsic carriers is $1.2 \times 10^{15} \text{ m}^{-3}$, the number density of electrons in it is 1
- (a) $1.8 \times 10^9 \text{ m}^{-3}$ (b) $2.4 \times 10^{10} \text{ m}^{-3}$
(c) $3.6 \times 10^9 \text{ m}^{-3}$ (d) $3.2 \times 10^{10} \text{ m}^{-3}$
11. A cell of emf E is connected across an external resistance R . When current 'I' is drawn from the cell, the potential difference across the electrodes of the cell drops to V . The internal resistance 'r' of the cell is 1
- (a) $\left(\frac{E - V}{E}\right) R$ (b) $\left(\frac{E - V}{R}\right)$
(c) $\frac{(E - V) R}{I}$ (d) $\left(\frac{E - V}{V}\right) R$
12. A photon of wavelength 663 nm is incident on a metal surface. The work function of the metal is 1.50 eV. The maximum kinetic energy of the emitted photo electrons is 1
- (a) $3.0 \times 10^{-20} \text{ J}$
(b) $6.0 \times 10^{-20} \text{ J}$
(c) $4.5 \times 10^{-20} \text{ J}$
(d) $9.0 \times 10^{-20} \text{ J}$





13. इलेक्ट्रॉनों और प्रोटॉनों के पुंज समान दिशा में एक दूसरे के समान्तर गतिमान हैं। इन दोनों के बीच 1
- (a) आकर्षण बल होगा।
(b) प्रतिकर्षण बल होगा।
(c) न तो आकर्षण बल होगा और न ही प्रतिकर्षण बल होगा।
(d) आकर्षण अथवा प्रतिकर्षण बल पुंजों की चाल पर निर्भर करता है।
14. 600 nm तरंगदैर्घ्य की कोई प्रकाश की किरण वायु से किसी माध्यम में संचरण कर रही है। यदि इस माध्यम में तरंगदैर्घ्य 400 nm हो जाती है, तो माध्यम का अपवर्तनांक है – 1
- (a) 1.4
(b) 1.5
(c) 1.6
(d) 1.8
15. त्रिज्या 'a' के किसी सीधे लम्बे तार से कोई स्थायी धारा 'I' प्रवाहित हो रही है। इसकी अनुप्रस्थ-काट के क्षेत्रफल पर धारा एकसमान वितरित है। दूरी $\frac{a}{2}$ पर चुम्बकीय क्षेत्र \vec{B}_1 और दूरी 2a पर चुम्बकीय क्षेत्र \vec{B}_2 का अनुपात है 1
- (a) $\frac{1}{2}$ (b) 1
(c) 2 (d) 4

नोट : प्रश्न संख्या 16 से 18 में कथन दिए गए हैं – एक को **अभिकथन (A)** तथा दूसरे को **कारण (R)** लेवल किया गया है। इन प्रश्नों के सही उत्तरों का कोड (a), (b), (c) और (d) में से इस प्रकार चयन कीजिए :

- (a) अभिकथन (A) और कारण (R) दोनों सत्य हैं और कारण (R), अभिकथन (A) की सही व्याख्या है।
(b) अभिकथन (A) और कारण (R) दोनों सत्य हैं और कारण (R), अभिकथन (A) की सही व्याख्या नहीं है।
(c) अभिकथन (A) सत्य है और कारण (R) असत्य है।
(d) अभिकथन (A) असत्य है और कारण (R) भी असत्य है।





13. Beams of electrons and protons move parallel to each other in the same direction. They 1
- (a) attract each other.
(b) repel each other.
(c) neither attract nor repel.
(d) force of attraction or repulsion depends upon speed of beams.
14. A ray of light of wavelength 600 nm propagates from air into a medium. If its wavelength in the medium becomes 400 nm, the refractive index of the medium is 1
- (a) 1.4 (b) 1.5
(c) 1.6 (d) 1.8
15. A long straight wire of radius 'a' carries a steady current 'I'. The current is uniformly distributed across its area of cross-section. The ratio of magnitude of magnetic field \vec{B}_1 at $\frac{a}{2}$ and \vec{B}_2 at distance 2a is 1
- (a) $\frac{1}{2}$ (b) 1
(c) 2 (d) 4

Note : In question number 16 to 18 two statements are given – one labelled **Assertion (A)** and the other labelled **Reason (R)**. Select the correct answer to these questions from the codes (a), (b), (c) and (d) as given below :

- (a) Both Assertion (A) and Reason (R) are true and Reason (R) is the correct explanation of Assertion (A).
(b) Both Assertion (A) and Reason (R) are true and Reason (R) is NOT the correct explanation of Assertion (A).
(c) Assertion (A) is true and Reason (R) is false.
(d) Assertion (A) is false and Reason (R) is also false.





16. **अभिकथन (A)** : किसी विद्युत क्षेत्र में किसी बन्द पथ के चारों ओर किसी आवेश को गमन कराने में किया गया कार्य शून्य होता है ।

कारण (R) : स्थिरविद्युत बल संरक्षी बल होता है ।

1

17. **अभिकथन (A)** : यंग के द्विझिरी प्रयोग में सभी फ्रिन्जों की चौड़ाई समान होती है ।

कारण (R) : फ्रिंज चौड़ाई उपयोग किए गए प्रकाश की तरंगदैर्घ्य (λ), पर्दे की झिरियों के तल से दूरी (D) और झिरियों के पृथकन (d) पर निर्भर करती है ।

1

18. **अभिकथन (A)** : प्रतिचुम्बकीय पदार्थ चुम्बकत्व दर्शाते हैं ।

कारण (R) : प्रतिचुम्बकीय पदार्थों में स्थायी चुम्बकीय द्विध्रुव आघूर्ण नहीं होता है ।

1

खण्ड – ख

19. यंग के द्विझिरी प्रयोग में दो झिरियों का पृथकन d तथा झिरियों से पर्दे के बीच की दूरी 1000 d है । यदि केन्द्रीय उच्चिष्ठ से प्रथम निम्निष्ठ की दूरी d है, तो d और λ के बीच संबंध प्राप्त कीजिए ।

2

20. $T > 0$ K के लिए किसी n-प्रकार और p-प्रकार के अर्धचालकों के लिए ऊर्जा बैंड आरेख खींचिए ।

2

21. निम्नलिखित का कारण देते हुए उत्तर दीजिए :

2

(i) किसी प्रबल धारा द्वारा कोई p-n संधि डायोड क्षतिग्रस्त हो जाता है ।

(ii) नैज अर्धचालकों में अशुद्धियों को मिलाया जाता है ।

22. (a) अवरक्त तरंगें किस प्रकार उत्पन्न होती हैं ? इन तरंगों को ऊष्मीय तरंगें क्यों कहा जाता है ? अवरक्त तरंगों के कोई दो उपयोग लिखिए ।

2

अथवा

(b) X-किरणें किस प्रकार उत्पन्न होती हैं ? इन किरणों के कोई दो उपयोग लिखिए ।

23. संक्षेप में व्याख्या कीजिए कि किसी गैल्वेनोमीटर को अमीटर में क्यों और किस प्रकार परिवर्तित किया जाता है ।

2



16. **Assertion (A) :** Work done in moving a charge around a closed path, in an electric field is always zero.
Reason (R) : Electrostatic force is a conservative force. 1
17. **Assertion (A) :** In Young's double slit experiment all fringes are of equal width.
Reason (R) : The fringe width depends upon wavelength of light (λ) used, distance of screen from plane of slits (D) and slits separation (d). 1
18. **Assertion (A) :** Diamagnetic substances exhibit magnetism.
Reason (R) : Diamagnetic materials do not have permanent magnetic dipole moment. 1

SECTION – B

19. In a Young's double slit experiment, the separation between the two slits is d and distance of the screen from the slits is $1000d$. If the first minima falls at a distance d from the central maximum, obtain the relation between d and λ . 2
20. Draw energy band diagram for an n-type and p-type semiconductor at $T > 0$ K. 2
21. Answer the following giving reasons : 2
- (i) A p-n junction diode is damaged by a strong current.
(ii) Impurities are added in intrinsic semiconductors.
22. (a) How are infrared waves produced ? Why are these waves referred to as heat waves ? Give any two uses of infrared waves. 2

OR

- (b) How are X-rays produced ? Give any two uses of these.
23. Briefly explain why and how a galvanometer is converted into an ammeter. 2

55/2/2

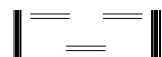

Page 11 of 24

P.T.O.



24. (a) आयनन ऊर्जा से क्या तात्पर्य है ? हाइड्रोजन परमाणु के लिए इसका मान लिखें । 2

अथवा

(b) द्रव्यमान क्षति की परिभाषा लिखिए । नाभिक के स्थायित्व से यह किस प्रकार संबंधित है ?

25. कोई बिन्दुकित बिम्ब वायु में 1.5 अपवर्तनांक के किसी अवतल गोलीय पृष्ठ के सामने 60 cm की दूरी पर सममिततः स्थित है । यदि इस पृष्ठ की वक्रता त्रिज्या 20 cm है, तो बनने वाले प्रतिबिम्ब की स्थिति ज्ञात कीजिए । 2

खण्ड – ग

26. किसी श्रेणी RL परिपथ, जिसमें $R = 10 \Omega$ तथा $L = \left(\frac{100}{\pi}\right) \text{mH}$ है, ac स्रोत वोल्टता $V = 141 \sin(100 \pi t)$ से संयोजित है, यहाँ V वोल्ट में तथा t सेकण्डों में है । परिकलित कीजिए

(a) परिपथ की प्रतिबाधा

(b) कला कोण, और

(c) प्रेरक के सिरों पर विभव पात 3

27. कोई प्रकाश किरण अपवर्तनांक μ तथा अपवर्तन कोण A के किसी काँच के प्रिज्म पर आपतन करती है । यदि यह किरण दूसरे पृष्ठ पर ठीक-ठीक पूर्ण आन्तरिक परावर्तन करती है तो आपतन कोण, प्रिज्म कोण तथा क्रांतिक कोण के बीच संबंध प्राप्त कीजिए । 3

28. (a) (i) प्रत्येक का एक-एक उदाहरण देकर नाभिकीय विखण्डन और नाभिकीय संलयन के बीच विभेदन कीजिए ।

(ii) बंधन ऊर्जा प्रति न्यूक्लियॉन वक्र के आधार पर नाभिकीय विखण्डन और नाभिकीय संलयन में ऊर्जा मुक्त होने की व्याख्या कीजिए । 3

अथवा

(b) (i) प्रयोग द्वारा नाभिक का साइज किस प्रकार ज्ञात किया जाता है ? किसी नाभिक की त्रिज्या और उसकी द्रव्यमान संख्या के बीच संबंध लिखिए ।

(ii) सिद्ध कीजिए कि किसी नाभिक का घनत्व उसकी द्रव्यमान संख्या पर निर्भर नहीं करता है ।



24. (a) What is meant by ionisation energy ? Write its value for hydrogen atom ? 2

OR

- (b) Define the term, mass defect. How is it related to stability of the nucleus ?
25. A point object in air is placed symmetrically at a distance of 60 cm in front of a concave spherical surface of refractive index 1.5. If the radius of curvature of the surface is 20 cm, find the position of the image formed. 2

SECTION – C

26. A series RL circuit with $R = 10 \Omega$ and $L = \left(\frac{100}{\pi}\right)$ mH is connected to an ac source of voltage $V = 141 \sin (100 \pi t)$, where V is in volts and t is in seconds. Calculate 3

- (a) impedance of the circuit
(b) phase angle, and
(c) voltage drop across the inductor

27. A ray of light is incident on a glass prism of refractive index μ and refracting angle A . If it just suffers total internal reflection at the other face, obtain a relation between the angle of incidence, angle of prism and critical angle. 3

28. (a) (i) Distinguish between nuclear fission and fusion giving an example of each.
(ii) Explain the release of energy in nuclear fission and fusion on the basis of binding energy per nucleon curve. 3

OR

- (b) (i) How is the size of a nucleus found experimentally ? Write the relation between the radius and mass number of a nucleus.
(ii) Prove that the density of a nucleus is independent of its mass number.



29. दो सेलों को जिनके emf E_1 और E_2 तथा आन्तरिक प्रतिरोध क्रमशः r_1 और r_2 हैं, पार्श्व में एक दूसरे के समान ध्रुवों से संयोजित किया गया है। इस संयोजन के तुल्य emf के लिए व्यंजक प्राप्त कीजिए। 3

30. (a) दो आवेशित चालक गोले जिनकी त्रिज्या a और b हैं किसी तार द्वारा एक दूसरे से संयोजित हैं। इनके पृष्ठों पर विद्युत क्षेत्रों का अनुपात ज्ञात कीजिए। 3

अथवा

(b) धारिता C के किसी समान्तर पट्टिका संधारित्र (A) को किसी बैटरी द्वारा वोल्टता V तक आवेशित किया गया है। इस संधारित्र से बैटरी को असंबद्ध करके 2C धारिता के किसी अनावेशित संधारित्र (B) को संधारित्र के सिरों से संबद्ध कर दिया गया है। ज्ञात कीजिए :

(i) A और B पर अंतिम आवेशों का अनुपात

(ii) अन्तिमतः A और B में संचित कुल स्थिरविद्युत ऊर्जा और आरम्भ में A में संचित ऊर्जा का अनुपात

खण्ड – घ

31. (a) (i) हाइगेन्स-सिद्धान्त लिखिए। आरेख की सहायता से यह दर्शाइए कि कोई समतल तरंग किसी पृष्ठ से कैसे परावर्तित होती है। इसका उपयोग करके परावर्तन के नियम का सत्यापन कीजिए। 5

(ii) 12 cm फोकस दूरी का कोई अवतल दर्पण किसी बिम्ब का तीन गुना आवर्धित आभासी प्रतिबिम्ब बनाता है। दर्पण से बिम्ब की दूरी ज्ञात कीजिए।

अथवा

(b) (i) अपवर्ती दूरदर्शक द्वारा प्रतिबिम्ब बनना दर्शाने के लिए नामांकित किरण आरेख खींचिए। इसकी आवर्धन क्षमता की परिभाषा लिखिए। परावर्ती दूरदर्शक की तुलना में अपवर्ती दूरदर्शक की दो सीमाएँ लिखिए।

(ii) किसी संयुक्त सूक्ष्मदर्शी के अभिदृश्यक और नेत्रिका लेंसों की फोकस दूरियाँ क्रमशः 1.0 cm और 2.5 cm हैं। 300 आवर्धन प्राप्त करने के लिए इस सूक्ष्मदर्शी की नलिका की लम्बाई ज्ञात कीजिए।



29. Two cells of emf E_1 and E_2 and internal resistances r_1 and r_2 are connected in parallel, with their terminals of the same polarity connected together. Obtain an expression for the equivalent emf of the combination. **3**

30. (a) Two charged conducting spheres of radii a and b are connected to each other by a wire. Find the ratio of the electric fields at their surfaces. **3**

OR

- (b) A parallel plate capacitor (A) of capacitance C is charged by a battery to voltage V . The battery is disconnected and an uncharged capacitor (B) of capacitance $2C$ is connected across A. Find the ratio of
- (i) final charges on A and B.
 - (ii) total electrostatic energy stored in A and B finally and that stored in A initially.

SECTION – D

31. (a) (i) State Huygen's principle. With the help of a diagram, show how a plane wave is reflected from a surface. Hence verify the law of reflection. **5**
- (ii) A concave mirror of focal length 12 cm forms a three times magnified virtual image of an object. Find the distance of the object from the mirror.

OR

- (b) (i) Draw a labelled ray diagram showing the image formation by a refracting telescope. Define its magnifying power. Write two limitations of a refracting telescope over a reflecting telescope.
- (ii) The focal lengths of the objective and the eye-piece of a compound microscope are 1.0 cm and 2.5 cm respectively. Find the tube length of the microscope for obtaining a magnification of 300.





32. (a) (i) गाउस नियम का उपयोग करके एकसमान रैखिक आवेश घनत्व λ के किसी अनन्ततः लम्बे सीधे पतले तार के कारण विद्युत क्षेत्र के लिए कोई व्यंजक प्राप्त कीजिए ।
- (ii) किसी अनन्ततः लम्बे धनावेशित सीधे तार का रैखिक आवेश घनत्व λ है । कोई इलेक्ट्रॉन इस तार को केन्द्र मानकर, वृत्ताकार पथ पर इस तार की परिक्रमा, तार के लम्बवत तल में किसी नियत चाल v से कर रहा है । आवेश के परिमाण और तार पर रैखिक आवेश घनत्व λ के पदों में इलेक्ट्रॉन की गतिज ऊर्जा ज्ञात कीजिए ।
- (iii) रैखिक आवेश घनत्व λ को फलन मानकर गतिज ऊर्जा के लिए ग्राफ खींचिए ।

5

अथवा

- (b) (i) दो सर्वसम बिन्दु आवेशों पर विचार कीजिए जो बिन्दुओं $(0, 0)$ और $(a, 0)$ पर स्थित हैं ।
- (1) क्या इन दोनों को जोड़ने वाली रेखा पर ऐसा कोई बिन्दु है जिस पर विद्युत क्षेत्र शून्य है ?
- (2) क्या इन दोनों को जोड़ने वाली रेखा पर ऐसा कोई बिन्दु है जिस पर विद्युत विभव शून्य है ?
- प्रत्येक प्रकरण के उत्तर की पुष्टि कीजिए ।
- (ii) आवेशों के निकाय की स्थिरविद्युत स्थितिज ऊर्जा के ऋणात्मक मान के महत्व का उल्लेख कीजिए ।

आरेख में दर्शाए अनुसार तीन आवेश 2.0 m भुजा के किसी समबाहु त्रिभुज ABC के शीर्षों पर स्थित हैं । इन तीनों आवेशों के निकाय की वैद्युत स्थितिज ऊर्जा परिकलित कीजिए ।

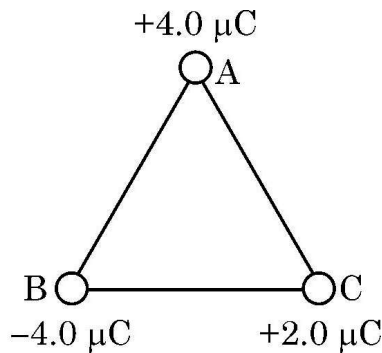



32. (a) (i) Use Gauss' law to obtain an expression for the electric field due to an infinitely long thin straight wire with uniform linear charge density λ .
- (ii) An infinitely long positively charged straight wire has a linear charge density λ . An electron is revolving in a circle with a constant speed v such that the wire passes through the centre, and is perpendicular to the plane, of the circle. Find the kinetic energy of the electron in terms of magnitudes of its charge and linear charge density λ on the wire.
- (iii) Draw a graph of kinetic energy as a function of linear charge density λ .

5

OR

- (b) (i) Consider two identical point charges located at points $(0, 0)$ and $(a, 0)$.
- (1) Is there a point on the line joining them at which the electric field is zero ?
- (2) Is there a point on the line joining them at which the electric potential is zero ?

Justify your answers for each case.

- (ii) State the significance of negative value of electrostatic potential energy of a system of charges.

Three charges are placed at the corners of an equilateral triangle ABC of side 2.0 m as shown in figure. Calculate the electric potential energy of the system of three charges.

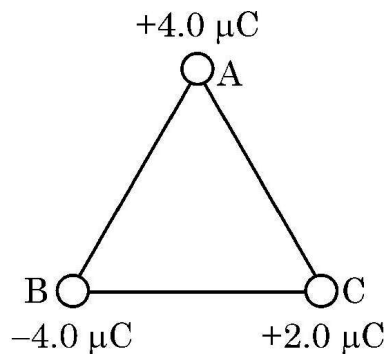



33. (a) (i) स्व-प्रेरण गुणांक की परिभाषा लिखिए । N फेरों वाली लम्बाई l तथा अनुप्रस्थ-काट क्षेत्रफल A की किसी परिनालिका के स्व-प्रेरकत्व के लिए व्यंजक प्राप्त कीजिए ।
- (ii) नीचे दिए गए आँकड़ों का उपयोग करके किसी कुण्डली का स्व-प्रेरकत्व परिकलित कीजिए । इन आँकड़ों को कुण्डली के सिरों पर $\left(\frac{200}{\pi}\right)$ Hz आवृत्ति के AC स्रोत और DC स्रोत को अनुप्रयुक्त करके प्राप्त किया गया है ।

5

AC स्रोत			DC स्रोत		
क्रम संख्या	V (वोल्ट)	I (एम्पियर)	क्रम संख्या	V (वोल्ट)	I (एम्पियर)
1	3.0	0.5	1	4.0	1.0
2	6.0	1.0	2	6.0	1.5
3	9.0	1.5	3	8.0	2.0

अथवा

- (b) (i) नामांकित आरेख की सहायता से किसी ac जनित्र के सिद्धान्त और कार्यविधि का वर्णन कीजिए । इसका उपयोग करके उत्पन्न emf के तात्क्षणिक मान के लिए व्यंजक व्युत्पन्न कीजिए ।
- (ii) किसी ac जनित्र की कुण्डली में तार के 100 फेरे हैं जिनमें प्रत्येक का क्षेत्रफल 0.5 m^2 है । तार का प्रतिरोध 100Ω है । यह कुण्डली अपने घूर्णन अक्ष के लम्बवत 0.8 T के चुम्बकीय क्षेत्र में 60 रेडियन प्रति सेकण्ड की नियत कोणीय चाल से घूर्णन कर रही है । इस कुण्डली में जनित अधिकतम emf और शक्ति क्षय परिकलित कीजिए ।

55/2/2

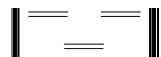

Page 18 of 24





33. (a) (i) Define coefficient of self-induction. Obtain an expression for self-inductance of a long solenoid of length l , area of cross-section A having N turns.
- (ii) Calculate the self-inductance of a coil using the following data obtained when an AC source of frequency $\left(\frac{200}{\pi}\right)$ Hz and a DC source is applied across the coil.

5

AC Source			DC Source		
S.No.	V (Volts)	I (A)	S.No.	V (Volts)	I (A)
1	3.0	0.5	1	4.0	1.0
2	6.0	1.0	2	6.0	1.5
3	9.0	1.5	3	8.0	2.0

OR

- (b) (i) With the help of a labelled diagram, describe the principle and working of an ac generator. Hence, obtain an expression for the instantaneous value of the emf generated.
- (ii) The coil of an ac generator consists of 100 turns of wire, each of area 0.5 m^2 . The resistance of the wire is 100Ω . The coil is rotating in a magnetic field of 0.8 T perpendicular to its axis of rotation, at a constant angular speed of 60 radian per second. Calculate the maximum emf generated and power dissipated in the coil.





खण्ड – ड

नोट : प्रश्न संख्या 34 और 35 केस आधारित प्रश्न हैं । नीचे दिए गए अनुच्छेद का अध्ययन करके प्रश्नों के उत्तर दीजिए ।

34. (a) दिए गए आरेख में किसी प्रकाश विद्युत सेल परिपथ में उसकी पट्टिकाओं के बीच विभवान्तर को फलन मानकर मापी गयी प्रकाश विद्युत धारा के विचरण को दर्शाया गया है जबकि सेल पर विभिन्न तरंगदैर्घ्यों के प्रकाश पुंज A, B, C और D आपतन करते हैं । दिए गए आरेख का परीक्षण कीजिए और निम्न प्रश्नों के उत्तर दीजिए ।

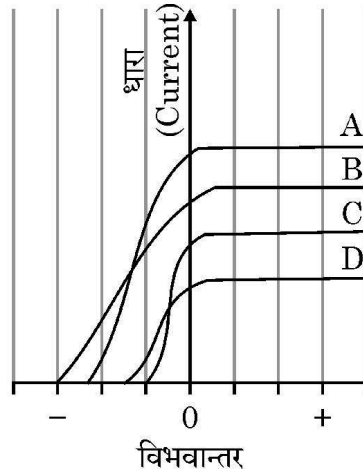

- किस प्रकाश पुंज की आवृत्ति उच्चतम है और क्यों ?
- किस प्रकाश पुंज की तरंगदैर्घ्य अधिकतम है और क्यों ?
- किस प्रकाश पुंज द्वारा सबसे अधिक संवेग से प्रकाशनज इलेक्ट्रॉन उत्सर्जित होते हैं और क्यों ?

4

अथवा

- (b) आपतित प्रकाश पुंज की आवृत्ति में वृद्धि करने पर देहली आवृत्ति और निरोधी विभव पर क्या प्रभाव होता है ? अपने उत्तर की पुष्टि कीजिए ।





SECTION – E

Note : Questions number 34 and 35 are case study based questions. Read the following paragraph and answer the questions.

34. (a) Figure shows the variation of photoelectric current measured in a photo cell circuit as a function of the potential difference between the plates of the photo cell when light beams A, B, C and D of different wavelengths are incident on the photo cell. Examine the given figure and answer the following questions :

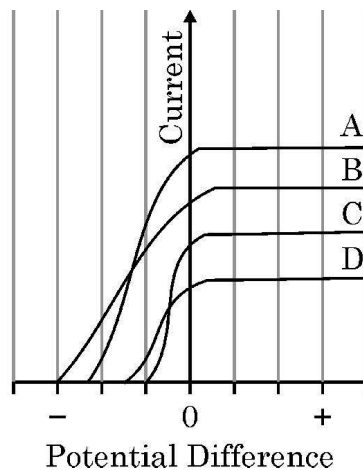

- Which light beam has the highest frequency and why ?
- Which light beam has the longest wavelength and why ?
- Which light beam ejects photoelectrons with maximum momentum and why ?

4

OR

- (b) What is the effect on threshold frequency and stopping potential on increasing the frequency of incident beam of light ? Justify your answer.





35. (a) आरेख में दर्शायी प्रायोगिक व्यवस्था पर विचार कीजिए। यह झंपन-वलय (Jumping Ring) प्रयोग भौतिकी के कुछ नियमों का उत्कृष्ट निदर्शन है। इसमें किसी अचुम्बकीय चालक पदार्थ के वलय को किसी परिनालिका के ऊर्ध्वाधर क्रोड पर रखा जाता है। जब परिनालिका से धारा प्रवाहित की जाती है, तो वलय ऊपर की ओर उछलता है।

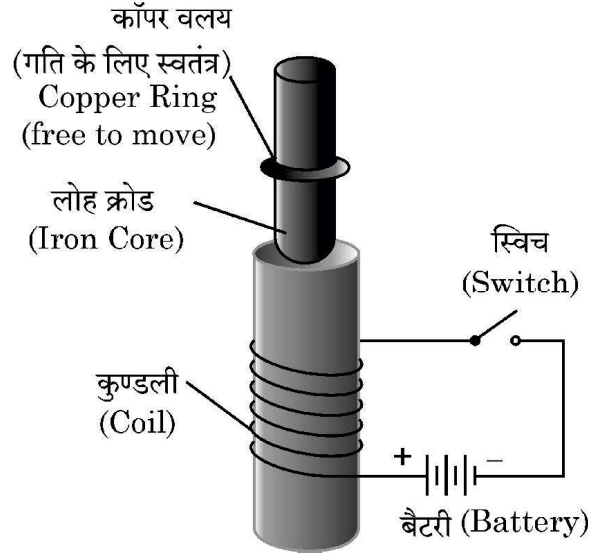

निम्न प्रश्नों के उत्तर दीजिए :

- जब परिपथ में स्विच को बन्द करते हैं तो वलय के झंपन के कारण की व्याख्या कीजिए।
- यदि बैटरी के टर्मिनलों को उत्क्रमित कर दें और फिर स्विच को बन्द करें तो क्या होगा ? व्याख्या कीजिए।
- इस परिघटना को समझने में सहायता करने वाले दो नियमों की व्याख्या कीजिए।

4

अथवा

- (b) किसी दी गई परिनालिका के चुम्बकीय क्षेत्र की प्रबलता में वृद्धि करने के विभिन्न उपायों की संक्षेप में व्याख्या कीजिए।



35. (a) Consider the experimental set up shown in the figure. This jumping ring experiment is an outstanding demonstration of some simple laws of Physics. A conducting non-magnetic ring is placed over the vertical core of a solenoid. When current is passed through the solenoid, the ring is thrown off.

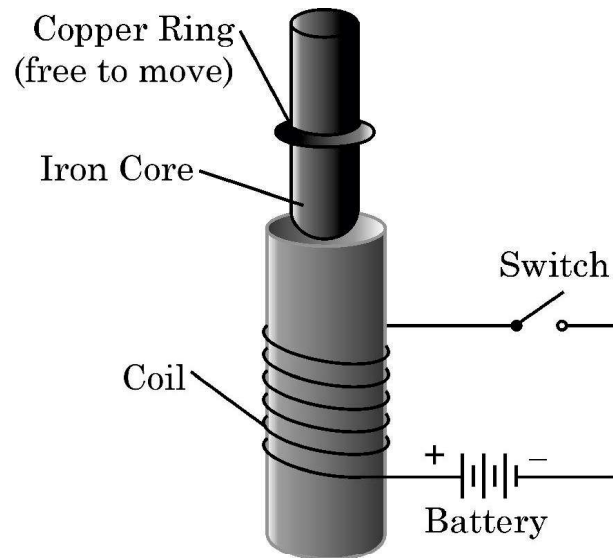

Answer the following questions :

- (i) Explain the reason of jumping of the ring when the switch is closed in the circuit.
- (ii) What will happen if the terminals of the battery are reversed and the switch is closed ? Explain.
- (iii) Explain the two laws that help us understand this phenomenon.

4

OR

- (b) Briefly explain various ways to increase the strength of magnetic field produced by a given solenoid.



Marking Scheme
Strictly Confidential
(For Internal and Restricted use only)
Senior School Certificate Examination, 2023
PHYSICS (SUBJECT CODE 042) (PAPER CODE 55/2/2)

General Instructions: -

1	You are aware that evaluation is the most important process in the actual and correct assessment of the candidates. A small mistake in evaluation may lead to serious problems which may affect the future of the candidates, education system and teaching profession. To avoid mistakes, it is requested that before starting evaluation, you must read and understand the spot evaluation guidelines carefully.
2	“Evaluation policy is a confidential policy as it is related to the confidentiality of the examinations conducted, Evaluation done and several other aspects. Its’ leakage to public in any manner could lead to derailment of the examination system and affect the life and future of millions of candidates. Sharing this policy/document to anyone, publishing in any magazine and printing in News Paper/Website etc may invite action under various rules of the Board and IPC.”
3	Evaluation is to be done as per instructions provided in the Marking Scheme. It should not be done according to one’s own interpretation or any other consideration. Marking Scheme should be strictly adhered to and religiously followed. However, while evaluating, answers which are based on latest information or knowledge and/or are innovative, they may be assessed for their correctness otherwise and due marks be awarded to them. In class-X, while evaluating two competency-based questions, please try to understand given answer and even if reply is not from marking scheme but correct competency is enumerated by the candidate, due marks should be awarded.
4	The Marking scheme carries only suggested value points for the answers These are in the nature of Guidelines only and do not constitute the complete answer. The students can have their own expression and if the expression is correct, the due marks should be awarded accordingly.
5	The Head-Examiner must go through the first five answer books evaluated by each evaluator on the first day, to ensure that evaluation has been carried out as per the instructions given in the Marking Scheme. If there is any variation, the same should be zero after deliberation and discussion. The remaining answer books meant for evaluation shall be given only after ensuring that there is no significant variation in the marking of individual evaluators.
6	Evaluators will mark(✓) wherever answer is correct. For wrong answer CROSS ‘X’ be marked. Evaluators will not put right (✓)while evaluating which gives an impression that answer is correct and no marks are awarded. This is most common mistake which evaluators are committing.
7	If a question has parts, please award marks on the right-hand side for each part. Marks awarded for different parts of the question should then be totaled up and written in the left-hand margin and encircled. This may be followed strictly.
8	If a question does not have any parts, marks must be awarded in the left-hand margin and encircled. This may also be followed strictly.
9	If a student has attempted an extra question, answer of the question deserving more marks should be retained and the other answer scored out with a note “Extra Question” .
10	No marks to be deducted for the cumulative effect of an error. It should be penalized only once.
11	A full scale of marks 0 - 70(example 0 to 80/70/60/50/40/30 marks as given in Question Paper) has to be used. Please do not hesitate to award full marks if the answer deserves it.

12	Every examiner has to necessarily do evaluation work for full working hours i.e., 8 hours every day and evaluate 20 answer books per day in main subjects and 25 answer books per day in other subjects (Details are given in Spot Guidelines). This is in view of the reduced syllabus and number of questions in question paper.
13	<p>Ensure that you do not make the following common types of errors committed by the Examiner in the past:-</p> <ul style="list-style-type: none"> ● Leaving answer or part thereof unassessed in an answer book. ● Giving more marks for an answer than assigned to it. ● Wrong totaling of marks awarded on an answer. ● Wrong transfer of marks from the inside pages of the answer book to the title page. ● Wrong question wise totaling on the title page. ● Wrong totaling of marks of the two columns on the title page. ● Wrong grand total. ● Marks in words and figures not tallying/not same. ● Wrong transfer of marks from the answer book to online award list. ● Answers marked as correct, but marks not awarded. (Ensure that the right tick mark is correctly and clearly indicated. It should merely be a line. Same is with the X for incorrect answer.) ● Half or a part of answer marked correct and the rest as wrong, but no marks awarded.
14	While evaluating the answer books if the answer is found to be totally incorrect, it should be marked as cross (X) and awarded zero (0) Marks.
15	Any un assessed portion, non-carrying over of marks to the title page, or totaling error detected by the candidate shall damage the prestige of all the personnel engaged in the evaluation work as also of the Board. Hence, in order to uphold the prestige of all concerned, it is again reiterated that the instructions be followed meticulously and judiciously.
16	The Examiners should acquaint themselves with the guidelines given in the “ Guidelines for spot Evaluation ” before starting the actual evaluation.
17	Every Examiner shall also ensure that all the answers are evaluated, marks carried over to the title page, correctly totaled and written in figures and words.
18	The candidates are entitled to obtain photocopy of the Answer Book on request on payment of the prescribed processing fee. All Examiners/Additional Head Examiners/Head Examiners are once again reminded that they must ensure that evaluation is carried out strictly as per value points for each answer as given in the Marking Scheme.

MARKING SCHEME: PHYSICS(042)

Code:55/2/2

Q.No.	VALUE POINTS/EXPECTED ANSWERS	Marks	Total Marks
SECTION A			
1	(c) c	1	1
2	(b) n=3 to n=2	1	1
3	(c) frequency	1	1
4	(b) Diffusion of both electrons and holes.	1	1
5	(d) 6 m	1	1
6	(d) more stable nucleus than its neighbours.	1	1
7	(b) 5.0×10^{17}	1	1
8	(b) C	1	1
9	(c) 3.6 W	1	1
10	(c) $3.6 \times 10^9 \text{ m}^{-3}$	1	1
11	(d) $\left(\frac{E-V}{V}\right)R$	1	1
12	(b) $6.0 \times 10^{-20} \text{ J}$	1	1
13	(b) Repel each other	1	1
14	(b) 1.5	1	1
15	(b) 1	1	1
16	(a) Both Assertion (A) and Reason (R) are true and Reason (R) is the correct explanation of the Assertion(A).	1	1
17	(a) Both Assertion (A) and Reason (R) are true and Reason (R) is the correct explanation of the Assertion(A).	1	1
18	(b) Both Assertion (A) and Reason (R) are true and Reason (R) is not the correct explanation of the Assertion (A).	1	1
SECTION - B			
19	<div style="border: 1px solid black; padding: 5px; margin-bottom: 10px;"> Obtaining relation between d & λ - 2 </div> <p>D=1000 d $x_{1d} = d$ Position of 1st minima. $x_{1d} = \frac{3}{2} \cdot \frac{\lambda D}{d}$ $d = \frac{3}{2} \cdot \frac{\lambda \times 1000d}{d}$ $\therefore d = 1500\lambda$</p>	$\frac{1}{2}$ 1 $\frac{1}{2}$	2
20	<div style="border: 1px solid black; padding: 5px;"> Drawing of energy band diagrams at T>0 K for <ul style="list-style-type: none"> • n-type semiconductor - 1 • p-type semiconductor - 1 </div>		

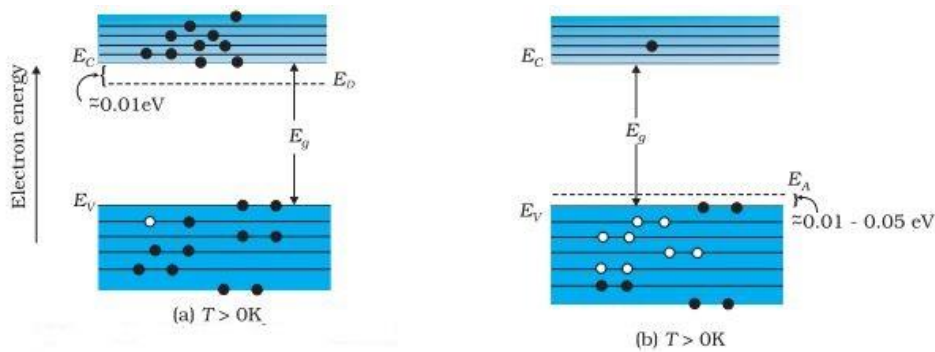

(a) n-type semiconductor

(b) p-type semiconductor

1+1

2

21

Reasons for

- | | | |
|---|---|---|
| i) Damage of a p-n junction diode by a strong current | - | 1 |
| ii) Adding impurities in intrinsic semiconductor | - | 1 |

- i) Due to strong current, a junction diode gets heated, consequently large number of covalent bonds are broken and the junction is damaged.
- ii) Deliberate addition of impurity atoms in intrinsic semiconductor increases its conductivity and is suitable for making electronic devices.

Alternatively

Give full credit if a student writes that no electronic device can be developed using intrinsic semiconductor because of their low conductivity.

1

1

2

22

- (a)
- | | | |
|--|---|-------------|
| Production of infrared waves | - | 1/2 |
| Reason of calling Infrared waves as heat waves | - | 1/2 |
| Two uses of Infrared waves | - | (1/2 + 1/2) |

Infrared waves are produced by hot bodies and vibrations of molecules. They are referred as heat waves because they are readily absorbed by water molecules and increase their thermal energy and heat them.

Uses

- 1) Dehydration of fruits.
 - 2) In greenhouse Effect.
 - 3) In remote switches.
- (any other relevant two uses)

OR

- (b)
- | | | |
|-----------------------|---|---------|
| Production of X- rays | - | 1 |
| Two uses of X- rays | - | 1/2+1/2 |

When fast moving electrons strike a heavy target like tungsten, X-rays are produced. Two uses –

1. Used as a diagnostic tool in medicine,

1/2

1/2

1/2 + 1/2

1

	<p>2. Treatment for certain forms of cancer.</p> <p>3. To study crystal structure.</p> <p>(Any two uses from above or other uses)</p>	$\frac{1}{2} + \frac{1}{2}$	2
23	<div style="border: 1px solid black; padding: 5px;"> <p>Explanation of conversion of galvanometer into an ammeter</p> <ul style="list-style-type: none"> • Why 1 • How 1 </div> <ul style="list-style-type: none"> • Due to very high sensitivity Alternatively It has large resistance and hence will change the value of current in circuit. • A galvanometer can be converted into an ammeter of desired range by connecting a shunt of proper value across its coil. 	1 1	2
24	<p>(a)</p> <div style="border: 1px solid black; padding: 5px;"> <p>Meaning of ionization energy - 1</p> <p>Value of ionization energy for hydrogen atom - 1</p> </div> <p>Ionization energy is the minimum energy required to remove an electron from an isolated atom of an element.</p> <p>Alternatively It is the energy required to excite an electron from energy level $n = 1$ to $n = \infty$ from an isolated atom of an element. The ionization energy for hydrogen atom is 13.6 eV.</p> <p style="text-align: center;">OR</p> <p>(b)</p> <div style="border: 1px solid black; padding: 5px;"> <p>Definition of mass defect - 1</p> <p>Its relation with stability - 1</p> </div> <p>Mass defect is the difference between the actual mass of the nucleus and the sum of the masses of its nucleons. Greater the mass defect, greater will be the binding energy and the nucleus will be more stable</p> <p>Alternatively Give full credit (1 mark) if a candidate writes, mass defect \propto stability of the nucleus.</p>	1 1 1 1	2
25	<div style="border: 1px solid black; padding: 5px;"> <p>Finding position of image - 2</p> </div> <p>$\mu = 1.5$, $u = -60$ cm , $R = -20$ cm , $v = ?$</p> $\frac{\mu}{v} - \frac{1}{u} = \frac{\mu - 1}{R}$ $\frac{1.5}{v} - \frac{1}{(-60)} = \frac{1.5 - 1}{(-20)}$ <p>$v = -36$ cm</p>	$\frac{1}{2}$ 1 $\frac{1}{2}$	2
SECTION - C			
26	<div style="border: 1px solid black; padding: 5px;"> <p>Calculation of</p> <ul style="list-style-type: none"> (a) Impedance - 1 (b) Phase angle - 1 (c) Voltage drop across the inductor - 1 </div>		

	<p>(a) $Z = \sqrt{R^2 + X_L^2}$, $X_L = \omega L$</p> $= \sqrt{100 + \left(100\pi \times \frac{100}{\pi} \times 10^{-3}\right)^2}$ $= 10\sqrt{2} \Omega$ <p>(b) $\tan \phi = \frac{X_L}{R}$</p> $= 1$ $\therefore \phi = \frac{\pi}{4} \text{ or } 45^\circ$ <p>(c) $V_{rms} = I_{rms} X_L$</p> $= \frac{141 \times 10}{\sqrt{2} \times 10\sqrt{2}}$ $= \frac{141}{2} \text{ V} = 70.5 \text{ V}$	$\frac{1}{2}$	$\frac{1}{2}$	$\frac{1}{2}$	$\frac{1}{2}$	
--	--	---------------	---------------	---------------	---------------	--

27	<div style="border: 1px solid black; padding: 5px; margin-bottom: 10px;"> <p>Obtaining a relation between angle of incidence , angle of prism and critical angle</p> <p style="text-align: right;">- 3</p> </div> <div style="text-align: center;"> </div> <p>∴ the light ray just suffers total internal reflection</p> <p>∴ $\angle r_2 = \angle i_c$</p> $A = r_1 + r_2$ $A = r_1 + i_c$ <p>From Snell's law at surface AB</p> $\sin i = \mu \sin r_1$ $\sin i = \mu \sin(A - i_c)$	1	$\frac{1}{2}$	$\frac{1}{2}$	$\frac{1}{2}$	$\frac{1}{2}$	3
----	---	---	---------------	---------------	---------------	---------------	---

28	<p>(a)</p> <table border="1" style="width: 100%;"> <tr> <td>(i) Difference between nuclear fission and nuclear fusion</td> <td style="text-align: right;">1</td> </tr> <tr> <td>Examples of each</td> <td style="text-align: right;">$\frac{1}{2} + \frac{1}{2}$</td> </tr> <tr> <td>(ii) Explanation of release of energy in nuclear fission & fusion</td> <td style="text-align: right;">$\frac{1}{2} + \frac{1}{2}$</td> </tr> </table> <p>Nuclear fission – It is a process in which a heavy nucleus when excited (say on bombarding by a slow moving neutron) splits into two lighter nuclei of nearly comparable masses with a release of large amount of energy.</p> <p>Example of nuclear fission</p>	(i) Difference between nuclear fission and nuclear fusion	1	Examples of each	$\frac{1}{2} + \frac{1}{2}$	(ii) Explanation of release of energy in nuclear fission & fusion	$\frac{1}{2} + \frac{1}{2}$	$\frac{1}{2}$					
(i) Difference between nuclear fission and nuclear fusion	1												
Examples of each	$\frac{1}{2} + \frac{1}{2}$												
(ii) Explanation of release of energy in nuclear fission & fusion	$\frac{1}{2} + \frac{1}{2}$												

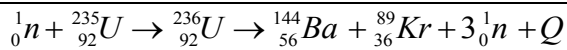

Nuclear Fusion - It is a process in which two lighter nuclei fuse (at extremely high temperature) to form a heavy nucleus and large amount of energy is released.

Examples of nuclear fusion

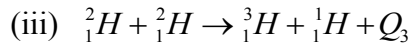
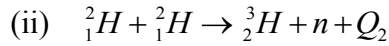
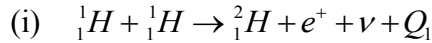

(any other possible reaction equation)

(ii) The binding energy per nucleon of the products in the nuclear reactions (nuclear fission and nuclear fusion) is greater than that of the reactants .

OR

(b)

(i) Experimental determination of size of nucleus of an atom	-	1/2
Relation between radius and mass number of nucleus	-	1
(ii) Proof of independence of density of nucleus on its mass number	-	1 1/2

(i) Size of nucleus of an atom is determined by scattering experiments in which fast electrons are used to bombard targets.

Relation between radius and mass number of nucleus.

$$R = R_0 A^{1/3}$$

(ii) Density of nucleus

$$\rho = \frac{\text{mass}}{\text{volume}}$$

$$\rho = \frac{m \times A}{\frac{4}{3} \pi R^3}$$

$$\rho = \frac{m A}{\frac{4}{3} \pi (R_0 A^{1/3})^3}$$

$$\rho = \frac{3m}{4\pi R_0^3}$$

Hence, density of nucleus is independent of mass number (A).

29

Obtaining expression for equivalent emf of two cells in parallel - 3

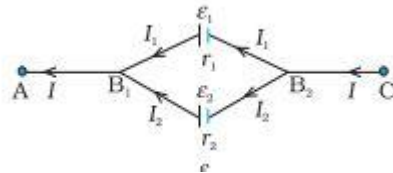

$$V \equiv V(B_1) - V(B_2) = \varepsilon_1 - I_1 r_1$$

$$V \equiv V(B_1) - V(B_2) = \varepsilon_2 - I_2 r_2$$

$$I = I_1 + I_2$$

	$I = \frac{\varepsilon_1 - V}{r_1} + \frac{\varepsilon_2 - V}{r_2}$ $I = \left(\frac{\varepsilon_1}{r_1} + \frac{\varepsilon_2}{r_2} \right) - V \left(\frac{1}{r_1} + \frac{1}{r_2} \right)$ $V = \frac{\varepsilon_1 r_2 + \varepsilon_2 r_1}{r_1 + r_2} - I \frac{r_1 r_2}{r_1 + r_2}$ $\therefore V = \varepsilon_{eq} - I r_{eq}$ $\varepsilon_{eq} = \frac{\varepsilon_1 r_2 + \varepsilon_2 r_1}{r_1 + r_2}$	1/2	
		1/2	3
30.	<p>(a) Finding ratio of the electric fields at their surfaces - 3</p> <p>When connected by a conducting wire both spheres will be at the same potential.</p> $\therefore k \frac{q_1}{a} = k \frac{q_2}{b}$ $\therefore \frac{q_1}{q_2} = \frac{a}{b}$ $\frac{E_1}{E_2} = \frac{k \frac{q_1}{a^2}}{k \frac{q_2}{b^2}}$ $\frac{E_1}{E_2} = \frac{b}{a}$ <p style="text-align: center;">OR</p> <p>(b) Finding the ratio of final charges on two capacitors A & B - 1/2 + 1/2 Ratio of electrostatic energy stored in A initially and in A and B finally - 1+1</p> <p>i) Initially $Q = CV$ Finally $q_A = C_A V_1$ & $q_B = C_B V_1$</p> $\frac{q_A}{q_B} = \frac{C_A}{C_B} = \frac{1}{2}$ <p>ii) $q_A + q_B = Q$ $\therefore q_A = \frac{Q}{3}$ & $q_B = \frac{2Q}{3}$</p> $\frac{U_f}{U_i} = \frac{U_A + U_B}{U_{Ai}}$ $= \frac{\frac{q_A^2}{2C_A} + \frac{q_B^2}{2C_B}}{\frac{Q^2}{2C_A}}$ $= \frac{1}{3}$ <p>Alternatively, Common potential</p>	1/2 1/2 1/2 1 1/2	



$$V_1 = \frac{Q_1 + Q_2}{C_1 + C_2}$$

$$= \frac{Q}{3C} = \frac{V}{3} \quad \left[\because \frac{Q}{C} = V \right]$$

$$\frac{U_f}{U_i} = \frac{\frac{1}{2} C_{eq} V_1^2}{\frac{1}{2} C_A V^2}$$

$$= \frac{\frac{1}{2} 3C \times \left(\frac{V}{3}\right)^2}{\frac{1}{2} C V^2} = \frac{1}{3}$$

1

 $\frac{1}{2}$ $\frac{1}{2}$

3

SECTION - D

31

(a)

(i) Statement of Huygen's principle	-	1
Diagram showing reflected wavefront	-	1
Verification of law of reflection	-	1
(ii) Finding distance of object from the mirror	-	2

(i) Huygen's principle

Each point of the wavefront is the source of a secondary disturbance and the wavelets emanating from these points spread out in all directions with the speed of the wave. These wavelets emanating from the wavefront are usually referred to as secondary wavelets, a common tangent to all these spheres gives the new position of the wavefront at a later time.

1

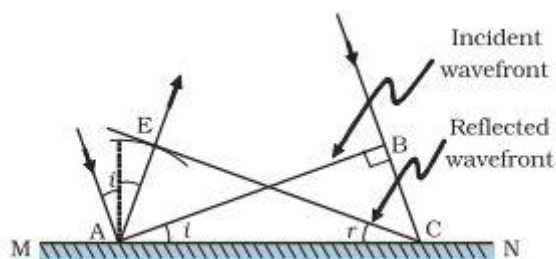

1

Verification of law of reflectionIn $\triangle AEC$ & $\triangle CBA$

$$EC = AB \quad (\text{c} \times \text{t each})$$

$$\angle AEC = \angle CBA \quad (90^\circ \text{ each})$$

$$AC = AC \quad (\text{common side})$$

By RHS congruency $\triangle AEC \cong \triangle CBA$

$$\Rightarrow \angle i = \angle r$$

(ii) $m = +3$, $f = -12$ cm, $u = ?$

$$m = -\frac{v}{u} = 3 \Rightarrow v = -3u$$

using mirror formula

$$\frac{1}{v} + \frac{1}{u} = \frac{1}{f}$$

$$\frac{1}{-3u} + \frac{1}{u} = \frac{1}{-12}$$

 $\frac{1}{2}$ $\frac{1}{2}$ $\frac{1}{2}$ $\frac{1}{2}$ $\frac{1}{2}$ 

$$u = -8 \text{ cm}$$

OR

(b)	(i)	Labelled diagram	-	1½
		Definition of magnifying power	-	1
		Two limitations	-	½ + ½
	(ii)	Finding tube length of microscope	-	1½

(i)

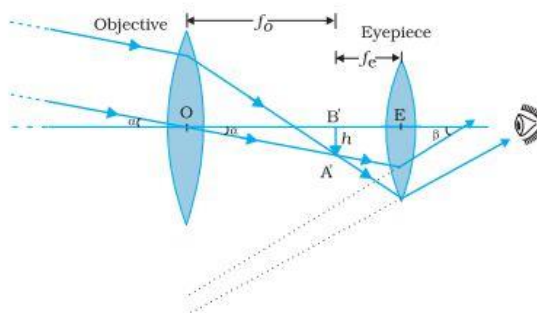

(Note deduct ½ mark if a student does not show the direction of propagation of the light.)

Alternatively

Give full credit for ray diagram if a candidate draws ray diagram for final image at the near point.

Magnifying power of a telescope – It is defined as the ratio the angle subtended at the eye by the final image to the angle subtended by the object at the lens or the eye.

Two limitations of a refracting telescope over a reflecting telescope.

- (i) Less resolving power.
- (ii) Difficult mechanical support.
- (iii) Less bright image.
- (iv) Suffers chromatic aberration.
- (v) Image suffers with spherical aberration.

(Any two of the above)

$$f_o = 1.0 \text{ cm} , f_e = 2.5 \text{ cm} , m = 300 , D = 25 \text{ cm} , L = ?$$

$$|m| = \frac{L}{f_o} \cdot \frac{D}{f_e}$$

$$300 = \frac{L}{1.0} \cdot \frac{25}{2.5}$$

$$L = 30 \text{ cm}$$

32

(a)	(i)	Derivation of the expression	-	2
		Finding kinetic energy of electron	-	2
		(iii) Graph	-	1

(i)

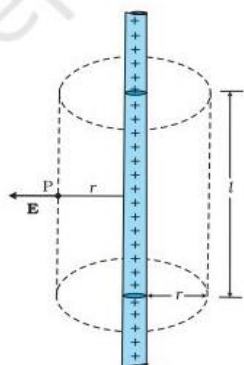

½

5

Flux through the Gaussian surface

$$\phi = E \cdot 2\pi r l$$

According to Gauss's law

$$E \cdot 2\pi r l = \frac{q}{\epsilon_0}$$

$$\therefore q = \lambda l$$

$$E = \frac{\lambda}{2\pi \epsilon_0 r}$$

$$(i) \quad E = \frac{\lambda}{2\pi \epsilon_0 r}$$

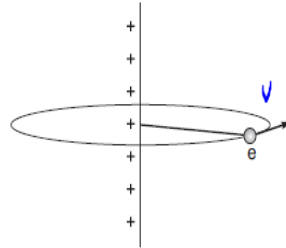

$$\frac{mv^2}{r} = eE$$

$$\begin{aligned} \therefore \text{Kinetic energy } K &= \frac{1}{2}mv^2 \\ &= \frac{1}{2}eEr \\ &= \frac{1}{2}e \frac{\lambda \cdot r}{2\pi \epsilon_0 r} = \frac{e\lambda}{4\pi \epsilon_0} \end{aligned}$$

$$(ii) \quad \text{Kinetic energy } K = \frac{e\lambda}{4\pi \epsilon_0}$$

$$\therefore K \propto \lambda$$

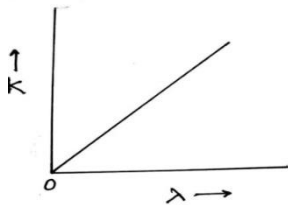

OR

(i)	Answers of (1) and (2) with justification	-	2
(ii)	Significance of negative value	-	1
	Determining electric potential energy	-	2

(i) (1) Yes, electric field is zero at mid point.

Electric field being a vector quantity, its resultant is zero.

(2) No, potential cannot be zero on line joining the charges.

Electric potential being a scalar quantity, the net potential due to two identical charges cannot be zero.

(ii) Negative value of electrostatic potential energy of a system signifies that the system has attractive forces.

Alternatively

Give full credit, if a candidate writes the system is stable /bound.

1/2

1/2

1/2

1/2

1/2

1/2

1/2

1

1/2

1/2

1/2

1/2

1

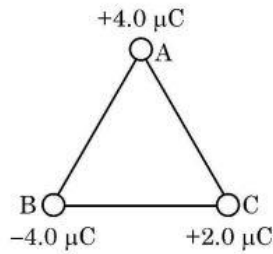

$$U = \frac{1}{4\pi\epsilon_0} \times \frac{q_1 q_2}{r}$$

$$U = \frac{1}{4\pi\epsilon_0} \left[\frac{q_A q_B}{r} + \frac{q_B q_C}{r} + \frac{q_C q_A}{r} \right]$$

$$= \frac{9 \times 10^9}{2} [-16 - 8 + 8] \times 10^{-12}$$

$$= -7.2 \times 10^{-2} J$$

1/2

1/2

1/2

1/2

5

33

- | | | |
|--|---|---|
| (i) Definition of coefficient of self induction | - | 1 |
| Derivation of expression for coefficient of self induction | - | 2 |
| (ii) Determining coefficient of self induction | - | 2 |

- (i) Coefficient of self induction is defined as the amount of magnetic flux associated with a coil when unit current flows through it.

Alternatively

It is defined as the magnitude of emf induced in a coil when current changes at the rate of 1 A/s through it.

- (ii) The magnetic field due to a current I flowing in solenoid is

$$B = \frac{\mu_0 N I}{l}$$

The total magnetic flux linked with solenoid

$$N\phi_B = (N) \left(\frac{\mu_0 N I}{l} \right) (A)$$

$$= \frac{\mu_0 N^2 I A}{l}$$

The self inductance is

$$L = \frac{N\phi_B}{I}$$

$$L = \frac{\mu_0 N^2 A}{l}$$

- (iii) From the table, $Z=6 \Omega$, $R=4 \Omega$

$$Z^2 = R^2 + X_L^2$$

$$X_L^2 = Z^2 - R^2 = 36 - 16 = 20$$

$$X_L = 2\sqrt{5} \approx 4.5 \Omega$$

$$2\pi\nu L = 4.5$$

$$L = \frac{4.5}{2 \times \pi \times \frac{200}{\pi}}$$

$$L = 1.1 \times 10^{-2} H = 11mH$$

Note : Please do not deduct marks if a student writes answer as

$$0.5\sqrt{5} \times 10^{-2} H$$

1

1/2

1/2

1/2

1/2

1/2

1/2

1/2

1/2



OR

(b)	(i) Labelled diagram	-	1
	Principle	-	1/2
	Working	-	1/2
	Obtaining expression of emf	-	1
	(ii) Determining		
	Maximum emf	-	1
	Power dissipated	-	1

(i) Diagram

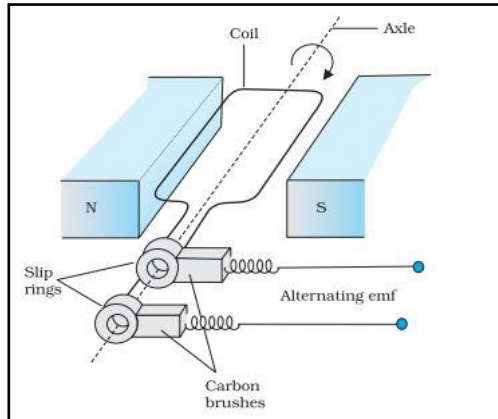

Principle – It is based on the principle of electromagnetic induction.

Whenever there is a change in magnetic flux linked with a coil, an emf is induced in the coil.

Alternatively

Give full credit if a candidate writes, it is based on the principle of electromagnetic induction.

Working - When a rectangular coil is rotated in a magnetic field, the magnetic flux changes continuously which induces an emf and the direction of current changes periodically.

$$\begin{aligned} \varepsilon &= \frac{-Nd\phi}{dt} \\ &= -NBA \frac{d}{dt}(\cos \omega t) \end{aligned}$$

$$\varepsilon = NBA\omega \sin \omega t$$

(ii) $\varepsilon_0 = NBA\omega$

$$\begin{aligned} &= 100 \times 0.8 \times 0.5 \times 60 \\ &= 2400 \text{ V} \end{aligned}$$

Power dissipated, $P = \frac{\varepsilon_{rms}^2}{R}$

$$\begin{aligned} &= \frac{\left(\frac{2400}{\sqrt{2}}\right)^2}{100} \\ &= 28.8 \text{ kW} \end{aligned}$$

Alternatively

Give full credit if a candidate calculates power dissipated using formula $\varepsilon_{rms} I_{rms}$ or $I_{rms}^2 R$.

1

1/2

1/2

1/2

1/2

1/2

1/2

SECTION - E

5

34	<div style="border: 1px solid black; padding: 5px;"> <p>(i) Identification of highest frequency beam and reason - ½ + ½ (ii) Identification of longest wavelength beam and reason - ½ + ½ (iii) Identification of beam ejecting photoelectrons with maximum momentum and reason - 1+1</p> <p style="text-align: center;">OR</p> <p>(b) Effect on threshold frequency and stopping potential on the increasing frequency and justification - 1+1</p> </div> <p>(i) The light beam B because it requires maximum retarding potential to reduce the photoelectric current to zero. ½ + ½ (ii) The light beam C because it requires minimum retarding potential to reduce photoelectric current to zero. ½ + ½ (iii) The light beam B ejects photoelectrons with maximum momentum. 1 because highest frequency light beam ejects photoelectrons with highest kinetic energy and hence highest momentum. 1</p> <p style="text-align: center;">OR</p> <p>There is no effect on threshold frequency since it is characteristic of the metal. ½ + ½</p> <p>With increase in frequency of incident beam of light, stopping potential increases because to stop the photoelectrons of higher kinetic energy, larger retarding potential is required. ½ + ½</p> <p>Alternatively Give full credit if a candidate explains the effect of frequency on stopping potential using the following formula. $eV_0 = h(\nu - \nu_0)$</p>		4
35.	<div style="border: 1px solid black; padding: 5px;"> <p>(i) Explanation of a jumping of ring - 1 (ii) Explanation of outcome on changing terminals of battery - 1 (iii) Explanation of two laws - 1+1</p> <p style="text-align: center;">OR</p> <p>(b) Two ways to increase strength of magnetic field produced by solenoid - 1+1</p> </div> <p>(i) The direction of induced current in the ring is such that the polarity developed in the ring is same as that of the polarity on the face of the coil, hence it will jump up due to repulsive force. 1 (ii) The polarity of the induced current in the ring will get reversed on changing the terminals of the battery, so the ring will jump again. 1 (iii) Lenz's law It states that the polarity of induced emf is such that it tends to produce a current which opposes the change in magnetic flux that produces it. 1 Faraday's law of EMI Whenever there is change in magnetic flux through a coil, an emf is induced. The magnitude of the induced emf in a coil is equal to the time rate of change of magnetic flux through the coil. 1</p> <p style="text-align: center;">OR</p> <p>Ways to increase strength of magnetic field produced by a solenoid. • By inserting soft iron core inside the solenoid. 1 • By increasing current in the solenoid. 1</p>		4

